

High Speed Jig Grinding Air Turbine Spindle

PLANET

Ultra-high-Speed & Super-Precision



About PLANET

Features



- A milling machine turns into a jig grinder by simply attaching a boring head available on the market and PLANET.
- If PLANET is mounted on a bench lathe, this grinder can be used as a precision internal grinder.
- PLANET can be used as a principal axis of an internal surface grinding device.

You can easily mount PLANET on a machine, so there is no need to buy a expensive high spec machine. If you use PLANET only when you need it, you can avoid idle time of a machine, and use a machine effectively and efficiently.

Rotation speed is 65,000min⁻¹, spindle run out is within 1μm. Planet realize high-precision jig grinding and mold machining.

Milling machine + PLANET = Jig Grinder

Rotation speed is 65,000min⁻¹, spindle run out is within 1μm.

Low price = No need to buy a expensive jig boring machine

Using your machine effectively and efficiently = Avoiding idle time of a machine

Connection drawing

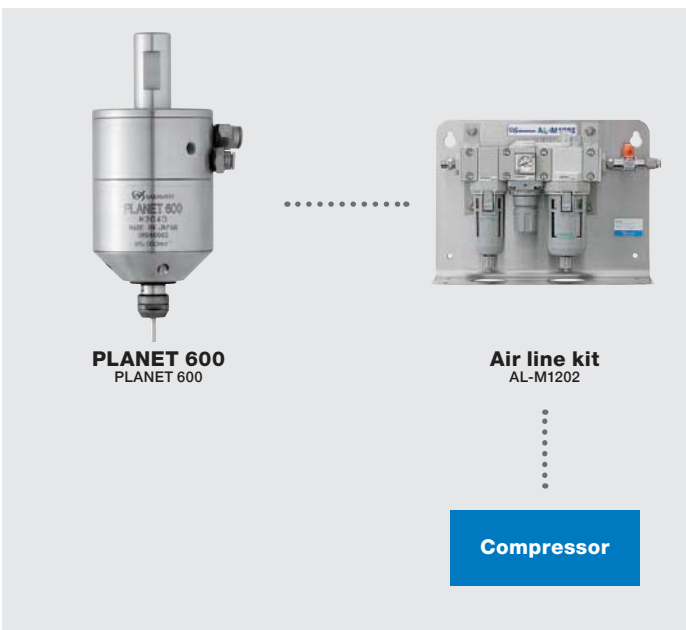

In case mounted on a lathe

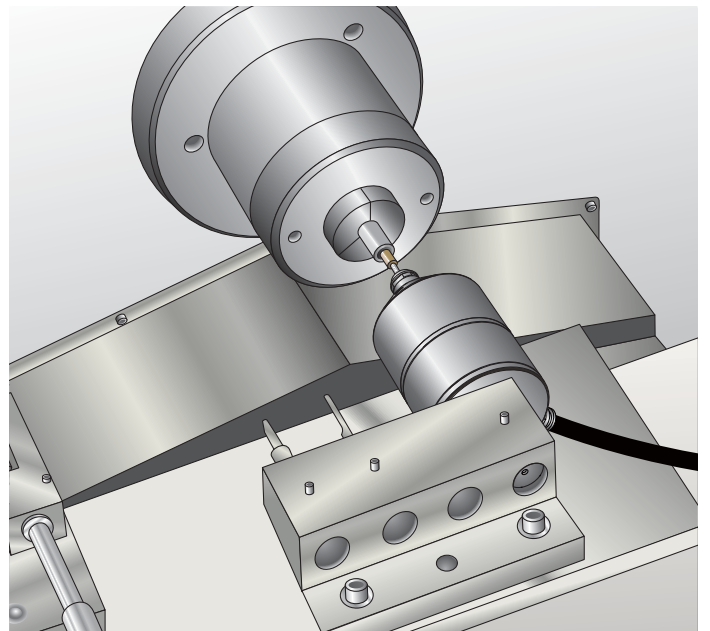

Save Your Cost

Save Your Time

Save Your Machine

Save Your Planet

Save The Planet

You can easily transform your conventional machines into high speed jig grinders with bolt-on setting.

You can also mount on lathe machines for precision internal grinding.



High Speed Jig Grinding Air Turbine Spindle

Ultra-high-Speed & Super-Precision

High Speed Jig Grinding Air Turbine Spindle

Not Actual Size

PLANET 600



Spec.

DXF data DXF files are available on our website

Code No.	7355	Model	PL600-M2040
Code No.	7356	Model	PL600-H3440

 Collet is sold separately.

O.D.	Max.rpm	Spindle runout	Proper air pressure	Collet	Air Consumption
PL600-M2040 $\varnothing 20$ mm PL600-H3440 $\varnothing 19.05$ mm	65,000 min ⁻¹	Within 1 μm	0.4 MPa	CHK Group ($\varnothing 0.5 \sim \varnothing 6.35$ mm)	175 Nl/min

Standard Accessories	Collet nut (K-265): 1pc./Spanner (12×14): 2pcs./Inlet Air Hose (K-254: $\varnothing 6$ mm×2m) with Filter Joint (FJ-01): 1pc./Silencer: 1pc./Anti-Swivel Bar: 1set
----------------------	--

Accessories

AL-M1202 (For $\phi 6\text{mm}$)

Air line kit

Code No. **4502** Model **AL-M1202**

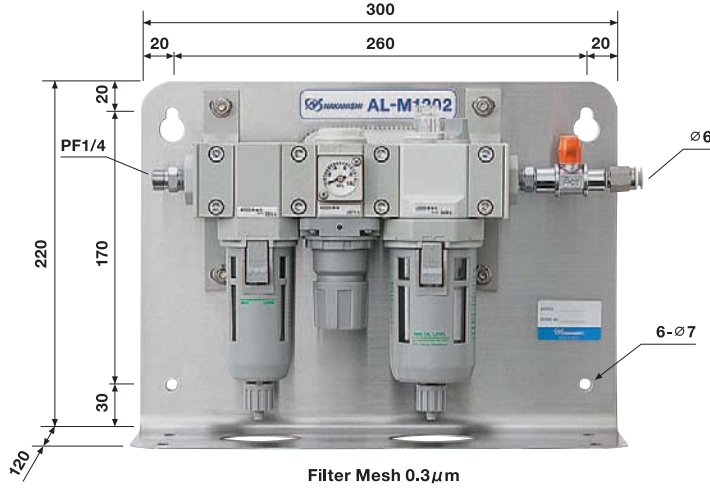

Standard Equipment Accessories Connection Hose (K-260) : 2m / Lubricating Oil (K-211) : 1pc. / Reducer

Collet	Code No.	Model	I.D
<p>Model : CHK-1.0, CHK-3.0, CHK-3.0AA, CHK-3.175, CHK-3.175AA, CHK-4.0, CHK-4.0AA, CHK-6.0, CHK-6.0AA, CHK-6.35, CHK-6.35AA</p>	91592	CHK-2.35	$\phi 2.35$
	91530	CHK-3.0	$\phi 3.0$
	91593	CHK-3.175	$\phi 3.175$
	91540	CHK-4.0	$\phi 4.0$
	91560	CHK-6.0	$\phi 6.0$
	91596	CHK-6.35	$\phi 6.35$
	-	CHK-□□	$\phi 0.5, \phi 0.6, \phi 0.7, \phi 0.8, \phi 0.9$ $\phi 1.0, \phi 1.5, \phi 2.0, \phi 2.5, \phi 3.5, \phi 4.5, \phi 4.76, \phi 5.5$ $\phi 1.1, \phi 1.2, \phi 1.3, \phi 1.4, \phi 1.7, \phi 1.8, \phi 1.9$ $\phi 2.1, \phi 2.2, \phi 2.3, \phi 2.4, \phi 2.6, \phi 2.7, \phi 2.8, \phi 2.9$ $\phi 3.1, \phi 3.2, \phi 3.3, \phi 3.4, \phi 3.6, \phi 3.7, \phi 3.8, \phi 3.9$ $\phi 4.1, \phi 4.2, \phi 4.3, \phi 4.4, \phi 4.6, \phi 4.7, \phi 4.8, \phi 4.9$ $\phi 5.1, \phi 5.2, \phi 5.3, \phi 5.4, \phi 5.6, \phi 5.7, \phi 5.8, \phi 5.9$
	91597	CHK-3.0AA	$\phi 3.0\text{AA}^*$
	91598	CHK-3.175AA	$\phi 3.175\text{AA}^*$
	91599	CHK-4.0AA	$\phi 4.0\text{AA}^*$
91600	CHK-6.0AA	$\phi 6.0\text{AA}^*$	
91601	CHK-6.35AA	$\phi 6.35\text{AA}^*$	

**High precision type AA (Spindle runout within $2\mu\text{m}$)*

Collet nut	Code No.	Model	Description
	2129	K-265	Collet nut for Collet CHK

Lubricating Oil	Code No.	Model	Description
	1057	K-211	Lubricating Oil (70cc)
	1058	K-202	Lubricating Oil (1L)



www.nakanishi-inc.com

NAKANISHI INC.

Headquarters · Factory

700 Shimohinata, Kanuma-Shi, Tochigi-Ken 322-8666
TEL 0289-64-3280 FAX 0289-62-1135

Tokyo Office

9F TIXTOWER UENO, 4-8-1, Higashiueno Taito-ku Tokyo 110-0015
TEL +81-3-5828-7740 FAX +81-3-5828-0064

Specifications and design are subject to change without notice.